

Concrete Road Construction Manual

Road Pavement Forum

*George
May 2009*

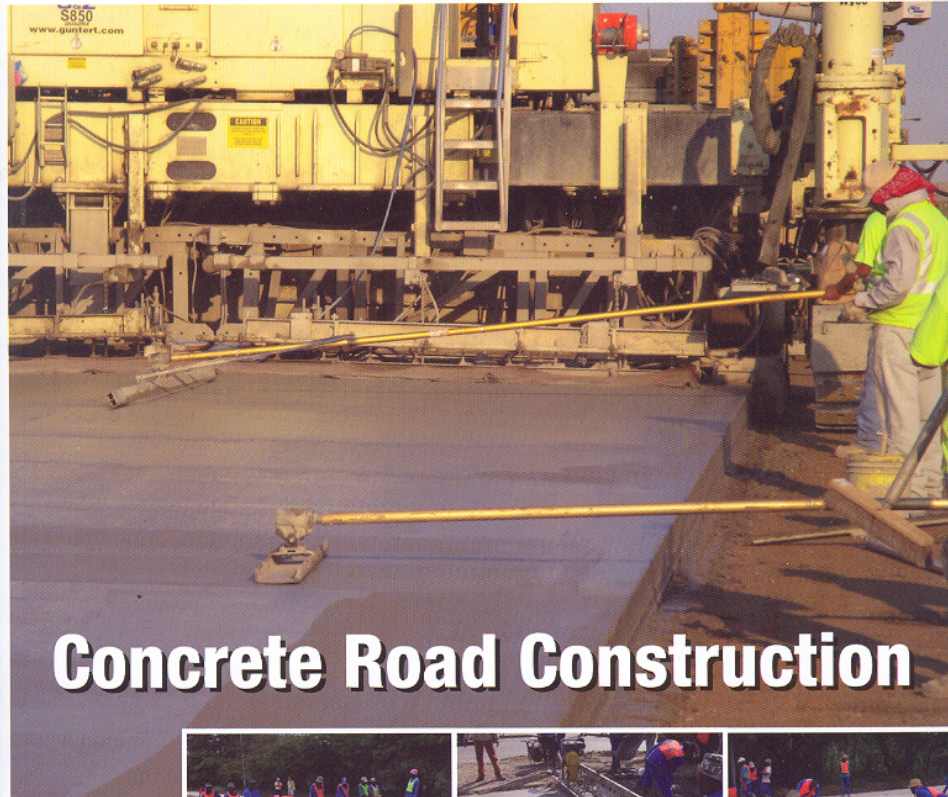

Concrete Road Construction



Acknowledgements

- **Dennis Rossmann**
- **Rick Mundy**
- **Dennis Brown**
- **Graham Selby**
- **Pieter Strauss**
- **Michael Kohlberg**

CONTENTS

- **Pavement Design**
- **Construction**

Pavement Design

- Pavement elements (including terminology)
- Concrete pavement types
- Function of concrete pavements
- Concrete pavement design and construction objectives
- Joints

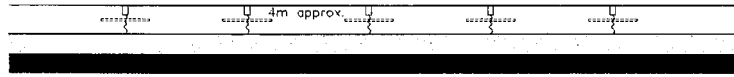

a. Jointed unreinforced (plain) concrete pavement with or without dowels

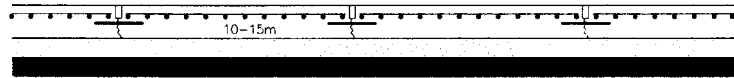

b. Jointed reinforced concrete pavement

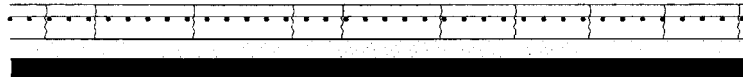

c. Continuously reinforced concrete pavement



d. Prestressed concrete pavement

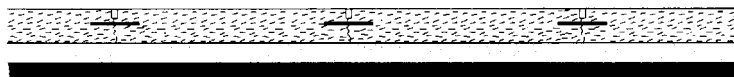

e. Fibre reinforced concrete pavement with or without dowels



f. Ultra thin continuously reinforced concrete pavement



g. Ultra thin reinforced concrete pavement

Construction

- **Paving Methods**
- **Subgrades and subbases**
- **Forms and stringlines**
- **Joint assemblies and reinforcement**
- **Concrete**
 - **Materials**
 - **Mix design**
 - **Production**

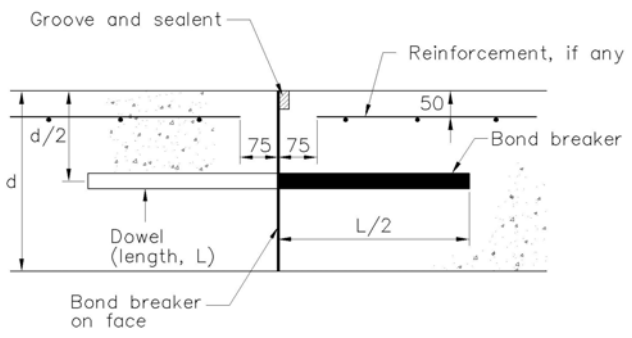
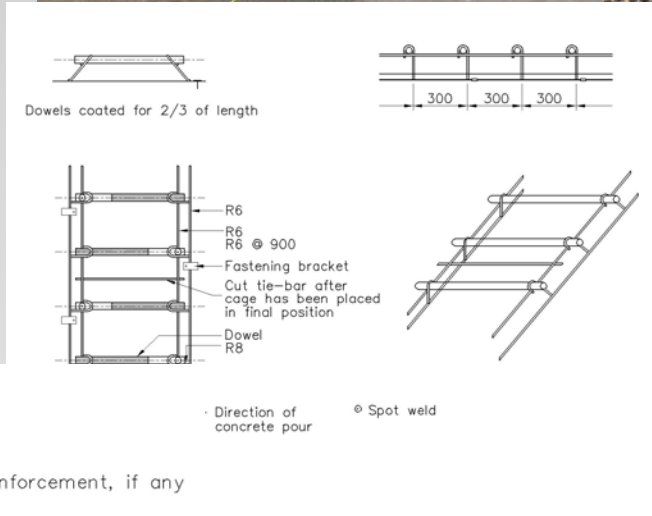

Figure 10B Dowelled butt joint



Construction (cont.)

- **Side form construction**
 - Mechanized
 - Hand
- **Slipform paving**
- **Finishing**
- **Texturing**
- **Protection and curing**





Construction (cont.)

- Joint construction
- Joint sealing
- Opening to traffic
- Tolerances
- Overlays
 - Asphalt
 - Concrete
- Inlays

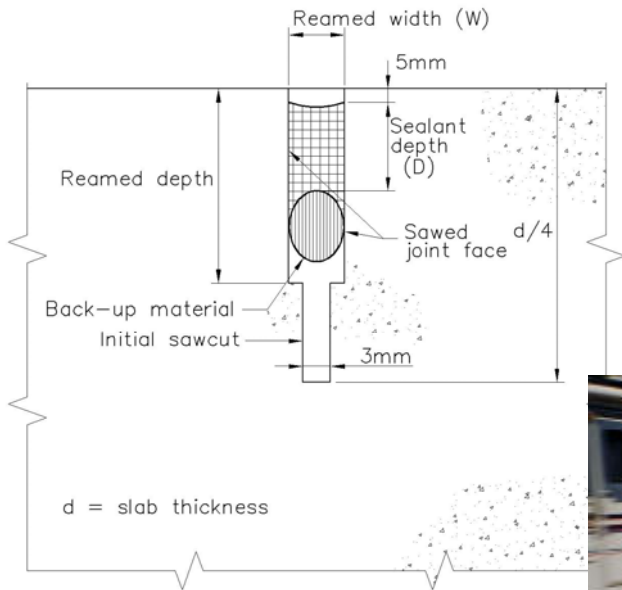

Figure 137



Construction (cont.)

- **Fasttracking**
- **Annexures**
 - **Mix proportioning**
 - **Quality control**
 - **Trial sections**
 - **Checklist for trial sections**

www.cnci.org.za

harry.mabaso@cnci.org.za